

British Board of Agrément

Bucknalls lane
Garston, Watford
Herts WD25 9BA

Tel: 01923 665300 Fax: 01923 665301

e-mail: mail@bba.star.co.uk

website: www.bbacerts.co.uk



GUIDELINES DOCUMENT FOR THE ASSESSMENT AND CERTIFICATION OF CRACK SEALING SYSTEMS FOR HIGHWAYS

October 2010

This document may be revised to take into account improvements and amendments to test and assessment methods and material innovations. Readers are advised to contact the British Board of Agrément to check the latest edition.

Acknowledgements

This document is published under the HAPAS scheme (Highway Authorities Product Approval Scheme). The document has been compiled by SG2 (Specialist Group 2) and ratified by HiTAC (the Highways Technical Advisory Committee).

Representation on Specialist Group 2 (SG2):

British Board of Agrément (BBA)

County Surveyors Society (CSS)

Highways Agency (HA) - Also representing other Overseeing Organisations

Hot Extruded Sealant Association (HESA)

Institute of Asphalt Technology (IAT)

Local Government Technical Advisors Group (TAG)

Transport Research Laboratory (TRL)

Representation on the Highways Technical Advisory Group (HiTAC):

British Board of Agrément (BBA)

ADEPT (Association of Directors of Environment, Economy, Planning and Development)

Highways Agency (HA) - Also representing other Overseeing Organisations

Mineral Products Association (MPA)

Highways Term Maintenance Association (HTMA)

Civil Engineering Contractors Association (CECA)

HAPAS Guidelines

Terms and Conditions of Use

This Guideline is protected by copyright and the BBA owns such copyright.

Any Intellectual Property Rights in the content of this Guideline are owned by the BBA.

This Guideline has to be read, considered and used as a whole document – it may be misleading and will be incomplete to be selective.

You may view and read this Guideline, copy it to a local hard disk and print extracts for your own personal use and/or your own internal business purposes. If a copy is being passed to a third party, BBA's Intellectual Property Rights must be acknowledged. Use and copying of this Guideline is permitted only in accordance with these terms and conditions.

References in this Guideline to any Act of Parliament, Statutory Instrument, Directive or Regulation, British, European or International Standard, Code of Practice, manufacturers' instructions or similar publication, are references to such publication in the form in which it was current at the date of this Guideline.

This Guideline is valid only within the UK.

The BBA makes no warranties, representations or undertakings in respect of this Guideline. In no event will the BBA be liable for any direct or consequential loss or damage arising from its use or use of, or reliance on its content.

Table of Contents

| | |
|--|----|
| Acknowledgements | 2 |
| HAPAS Guidelines | 2 |
| List of Contents | 3 |
| Scope | 4 |
| Introduction | 5 |
| Assessment Procedure | 6 |
| Acceptance of Data Supplied by the Applicant | 10 |
| Bibliography | 10 |
| Appendix A Test Methods and Procedures | 11 |
| Appendix B Definitions and Acronyms | 14 |

Scope

1.1 The assessment is directed towards the issue of a BBA HAPAS Roads and Bridges Series Certificate confirming a Crack Sealing System's compliance with the requirements as defined by Specialist Group 2, Crack Sealing Systems for Highways, and agreed by HiTAC.

1.2 For the purpose of this scheme, a Crack Sealing System is defined as a proprietary system for repairing cracks in non-porous bituminous or concrete highway surfacings with texture depths(1) not exceeding 2 mm.

(1) Measured using the sand patch method in accordance with BS EN 13036-1: 2002.

1.3 A system must have a minimum initial Skid Resistance Value (SRV) of 60 measured using the portable skid resistance tester (narrow slider scale C) and procedures as defined in TRL Report 176.

1.4 For the purpose of this scheme the types of Crack Sealing Systems include:

- Simple Overband Systems for repairing crack widths up to 5 mm (See Figure 1a).
- Fill and Overband(2) Systems for repairing cracks between 5 mm and 40 mm wide. (See Figure 1b).
(2) The fill and overband components may comprise different materials.
- Inlaid Sealing Systems(3) for repairing a crack or adjacent multiple cracks. With these systems, the crack(s) are normally routed or planed out to form a recess and the sealant applied flush with the highway surface. (See Figures 1c and 1d). They may be used in conjunction with an edge overband that meets the requirements given in Tables 2, 3 and 4.
(3) These materials are categorised as either Grade F (Flexible) or Grade H (High Modulus).

Figure 1 Specifications

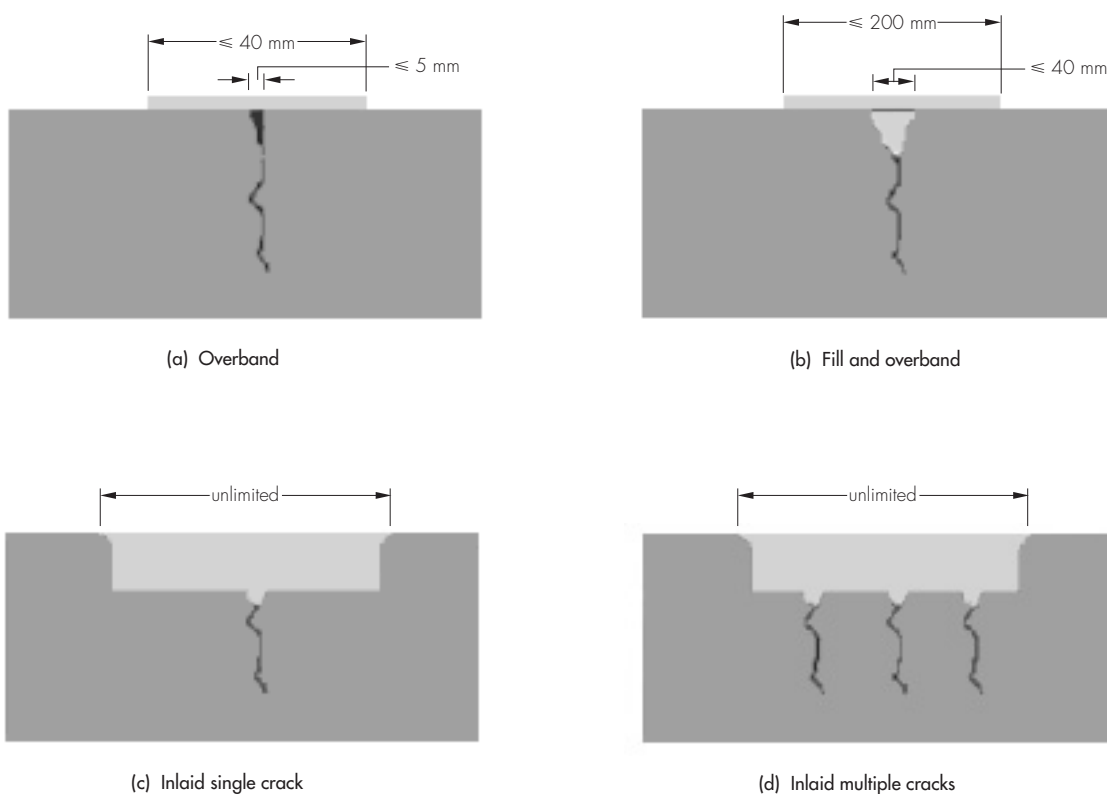

1.5 Systems receiving a Certificate will be recognised under the Highway Authorities Product Approval Scheme (HAPAS).

1.6 A condition of certification must be that systems are only installed by contractors approved by the Certificate holder.

1.7 A system's performance is measured against the parameters given in the appropriate Tables 3, 4 and 5. Systems complying with the requirements of this Guidelines Document have an expected service life(4) as detailed in Table 1. Any limitations will be stated in the Certificate.

(4) Where cracks have penetrated substantially through the pavement depth due to structural failure resulting in significant movement under traffic, no expectation of life can be predicted. Where pavements are structurally sound and cracking is confined to the surfacing layer or layers, and these remain bonded to the road-base, the minimum expected life should be achieved.

Under particularly onerous conditions (eg when subjected to heavy trafficking by commercial vehicles or unusually severe weather conditions), the minimum expected life may not be achieved.

Table 1: Performance tests and expected service life

| System type | Test | Expected service life (Years) |
|---|--|-------------------------------|
| Overband, and Fill and Overband Systems | Retention of SRV after wheel tracking at 50°C or 60°C | 3 or 5 |
| Inlaid systems | Rut Resistance and Retention of SRV after wheel tracking at 50°C | 5 |

Introduction

2.1 The Assessment procedure is undertaken in three stages:

Stage 1 - Assessment of Applicant's Data and Factory Production Control

Stage 2 - Laboratory Testing

Stage 3 - System Installation Trial

Stage 4 - Certification

2.2 Each stage must be successfully completed and, where appropriate, a report issued prior to the commencement of the next stage. However, Stages 1, 2 and 3 may be undertaken concurrently at the request of the Applicant. The Applicant shall have the option of withdrawing from the programme at any stage should the system submitted fail to comply with the requirements.

2.3 In the event of an Applicant offering a system including a number of options with regard to components and/or alternative application procedures, the BBA will define the number of Certificates required and the range of tests to be performed to allow the acceptance of the alternative materials and/or procedures.

2.4 The BBA in consultation with Specialist Group 2 reserves the right to amend or supplement the tests required for BBA Assessment and Certification at any time if required. The cost of all further tests will be borne by the Applicant.

2.5 A Certificate will only be awarded on the system's successful completion of the appropriate Stages 1 to 4.

Assessment Procedure

Stage 1: Assessment of Applicant's Data and Factory Production control

Assessment of Applicant's Data

3.1 Applicants will include the details listed below for examination by the BBA. If they are found to be acceptable they will form the basis of the subsequent assessment:

| | |
|--|---|
| Application for BBA assessment: | Applicant details and historical data for the system |
| Quality Plan: | details of the system to be assessed, production procedures (including controls and tolerances), location of all production plants. For example: <ul style="list-style-type: none">- binder (type, source, characteristics)- aggregate(s) (type, source, characteristics)- ancillary products (type, source, characteristics)- mix design parameters- final product (nominal thickness as laid and claimed regulation, composition, storage, delivery to and storage on site)- quality system information. |
| Installation procedures: | <ul style="list-style-type: none">- limitations in respect to weather and substrate conditions- substrate preparation- pre-installation survey details- installation details- details for maintenance and repair (including any special repair materials)- on-site storage and handling of materials- on site quality control / assurance procedures and associated documentation- audit checks on the installer(s) |
| CE Mark product information (if applicable): | <ul style="list-style-type: none">- Information confirming compliance to BS EN 13108- Data relating to type testing and factory production control in accordance with BS EN 13108 – 20 and 21- Type test reports indicating mixture constituents, composition and claimed properties- FPC certificate from a Notified Body. |

3.2 Should there be, during the assessment, the need to modify the system defined by the Applicant (eg. as a result of failure of the system to meet the requirements) the content of the assessment and additional work required will be reconsidered by the BBA.

3.3 If the system includes hazardous substances (ie that fall under the scope of the COSHH Regulations), the Applicant must supply all the relevant data. In terms of the COSHH regulations, no formal assessment of the suitability of this data is undertaken by the BBA. However, this data is always required to ensure the safe use and testing of the system in their laboratories. The Applicant's instructions for use must include all necessary data to allow the safe use of the product.

Assessment of Factory Production Control

3.4 The BBA will assess the Applicant's production processes, material controls, records etc to ensure that a consistent product is offered for sale. This includes (where relevant) a visit to the factory. The assessment of factory production control shall form the basis for subsequent surveillance visits.

3.5 Where registration to ISO 9001 exists this will be taken into full account during the assessment.

Stage 2: Laboratory Testing

Identification / Characterisation

3.6 All samples submitted for testing, are prepared by the Applicant or their representative. Preparation of samples maybe witnessed by the BBA or their agent. The Applicant must provide evidence that the system submitted for this stage is within the declared manufacturing tolerances (eg. Certificate of Conformity), including quality control data.

3.7 The BBA will undertake a series of tests to check that the characteristics of the system, and its various constituent parts, fall within the specification limits declared by the Applicant. These checks also serve to ensure that the system offered for assessment is typical and to enable confirmation, at a later date, that other samples also fall within the agreed specification.

3.8 The properties to be measured will depend heavily on the nature of the materials offered for assessment and the final test programme will be agreed in consultation with the Applicant.

Performance Testing

3.9 Testing is undertaken by a laboratory UKAS approved for the tests in accordance with the test methods, given in Table 2 on behalf of the BBA:

Table 2 Performance testing

| Test | Test Method |
|---|---|
| Overband, Fill and Overband and Inlaid systems binder tests⁽¹⁾: | |
| Cone penetration at 25°C on: control after heat ageing (at 70±2°C for 28 days) | BS EN 13880-2: 2003 |
| Resilience at 25°C: control after heat ageing (at 70±2°C for 28 days) | BS EN 13880-2: 2003 |
| Flow resistance (at 60±2°C) | BS EN 13880-5: 2003 |
| Overband System tests: | |
| Skid Resistance Value (SRV) | Appendix A, method 1 |
| Retention of SRV, Spread and Thickness after wheel tracking | Appendix A, method 2 |
| Tensile bond to asphalt, and concrete ⁽²⁾ : control heat ageing at (70±2°C for 28 days) | TRL Report 176 Appendix J |
| Fill and Overband System Tests: | |
| Skid Resistance Value (SRV) | Appendix A, method 1 |
| Texture depth ⁽³⁾ | Appendix A, method 5 |
| Retention of texture depth ⁽³⁾ and SRV after wheel tracking | Appendix A, method 2 or Appendix A, method 3 ⁽⁴⁾ |
| Spread and thickness of the overband component after wheel tracking | Appendix A, method 2 or Appendix A, method 3 |
| Tensile bond to asphalt, and concrete ⁽²⁾ : control after heat ageing (at 70±2°C for 28 days) | TRL Report 176 Appendix J |
| Flow rate of fill material (hot poured systems only) over manufacturer's declared application temperature range | Zahn Cup, Appendix A, method 6 |
| Inlaid Sealing System tests: | |
| Skid resistance value (SRV) | Appendix A, method 1 |
| Texture depth | Appendix A, method 5 |
| Rut depth | Appendix A, method 4 |
| Rut rate and retention of SRV | |
| Texture depth after wheel tracking | |
| Tensile bond to asphalt, and concrete ⁽²⁾ : control after heat ageing (at 70±2°C for 28 days) | TRL Report 176 Appendix J |
| Elongation (Grade F (flexible) materials only) | Appendix A, method 7 |
| Yield strain (Grade H (high modulus) materials only) | Appendix A, method 8 |

(1) All tests to be conducted on bituminous base binder(s) without added filler/aggregate, prior to manufacture. Where this is not possible or the binder is non bituminous in nature, other tests may be carried out. These will be agreed between the BBA and the applicant.

(2) if requested

(3) Texture depth measurements only required where overband component is applied >40 mm wide.

(4) Method 2 should be used for systems where maximum crack widths of 20 mm apply.

Performance requirements

3.10 The requirements for bituminous binders are given in Table 3.

Table 3 Requirements for bituminous binders⁽¹⁾

| Test | Requirements | | | |
|------------------------|------------------------|------------------------|------------------------|------------------------|
| | Overband | Fill and Overband | Inlaid | |
| | | | Grade F | Grade H |
| Cone Penetration (dmm) | | | | |
| - Initial | ≥ 35 | ≥ 35 | ≥ 25 | ≥ 10 |
| - Heat aged | ≥ 60% of initial value | ≥ 60% of initial value | ≥ 60% of initial value | ≥ 60% of initial value |
| Resilience (%) | | | | |
| - Initial | Record value | | | |
| - Heat aged | ≥ 60% of initial value | | | |
| Flow (mm) | ≤ 2 | | | |

(1) All tests to be conducted on bituminous base binder(s) without added filler/aggregate, prior to manufacture. Where this is not possible or the binder is non bituminous in nature, other tests may be carried out. These will be agreed between the BBA and the applicant.

Systems requirements

3.11 The requirements for an Overband or Fill and Overband System are given in Table 4.

Table 4 Requirements for Overbanding and Fill and Overbanding systems

| Test | Parameter | Requirements |
|---|---|-----------------------------|
| Skid Resistance Value (SRV) | Initial SRV | ≥ 60 |
| Texture depth ⁽¹⁾ | Initial texture depth | ≥ 1.5 |
| Wheel tracking ⁽²⁾ at 50°C or 60°C | Spread after wheel tracking (mm) | Record value |
| | Thickness before and after wheel tracking (mm) | Record value |
| | SRV after wheel tracking | ≥ 50 |
| | Texture depth after wheel tracking (mm) ⁽¹⁾ | ≥ 0.75 |
| Tensile bond strength (N·mm ⁻²) | Initial | ≥ 0.50 |
| | Heat aged | ≥ 60% of initial value |
| Flow rate (s) ⁽³⁾ | Efflux time over manufacturer's declared application temperature range. | Record values |
| | Temperature for 20 s efflux time | Record value ⁽⁴⁾ |
| Elongation(%) ⁽⁵⁾ | Elongation (maximum load 1000 N) | ≥ 30 |

(1) Texture depth measurements only required where overband component is applied >40 mm wide.

(2) The life expectancy of a system used in an appropriate location is a minimum of 3 or 5 years (see Table 1).

(3) Only required on the fill component of fill and overband systems.

(4) The temperature for an efflux time of 20 seconds is considered as the minimum recommended temperature for filling cracks between 5 mm and 20 mm and should lie at the lower end of the manufacturer's declared application temperature range.

(5) Only required for fill component of Fill and Overband systems.

3.12 The requirements for an Inlaid System are given in Table 5. The life expectancy of a system used in an appropriate location is a minimum of 5 years (see Table 1).

Table 5 Requirements for Inlaid systems

| Test | Parameter | Requirements | |
|--|---|------------------------|---------|
| | | Grade F | Grade H |
| Skid Resistance Value (SRV) | Initial SRV | ≥ 60 | |
| Texture depth | Initial texture depth (mm) | ≥ 1.5 | |
| Wheel tracking(1) at 50°C | Rut rate (mm h-1) | ≤ 5.0 | ≤ 5.0 |
| | Rut depth (mm) | ≤ 10.0 | ≤ 7.0 |
| | SRV after wheel tracking | ≥ 50 | ≥ 50 |
| | Texture depth after wheel tracking (mm) | ≥ 0.75 | ≥ 0.75 |
| Tensile bond strength (N·mm ²) | Initial | ≥ 0.50 | |
| | Heat aged | ≥ 60% of initial value | |
| Elongation (%) | Elongation (maximum load 1000 N) | ≥ 30 | N/A |
| Yield strain (%) | Yield strain | N/A | ≥ 2.5 |

(1) The life expectancy of a system used in an appropriate location is a minimum of 5 years (see Table 1).

Stage 3: System Installation Trial

3.13 The Applicant must arrange for the System Installation Trial during daylight hours to demonstrate the installation, quality assurance, repairs and maintenance techniques to enable verification of their claims.

3.14 The trial will be witnessed and assessed by the BBA to cover the Applicant's installation methods as defined in their Installation Method Statement.

3.15 The Installation Method Statement must be practicable and sufficiently detailed to cover all foreseen eventualities and includes:

- the application rates
- methods of verification to be used on site
- maintenance and repair techniques
- aftercare
- frequency of testing
- acceptable variations within the specified limits.

3.16 The BBA will inspect the site to assess the condition of the system by visual observation.

Stage 4: Certification

3.17 Any Certificate issued will be in BBA HAPAS Roads and Bridges Product Sheet format and will verify the system's compliance with the requirements given in this document. The Certificate will also define the system assessed, the conditions of use and the likely performance related to the severity of the conditions of use. It will also include the results of tests.

3.18 The assessment and any Certificate issued is subject to the Terms and Conditions of the relevant BBA Contract which can be found on the BBA website: www.bbacerts.co.uk that includes:

- Any Certificate issued will have an unlimited validity provided that:
 - The specification of the system is unchanged by the manufacturer
 - The manufacturer continues to have the system checked by the BBA, which will include ongoing surveillance of production
 - The validity is confirmed by a Review carried out every five years by the BBA. The validity of a Certificate can be checked by referring to the BBA's website: www.bbacerts.co.uk
 - The requirements of the Guidelines Document remain unchanged.
- In the event of the Certificate Holder going into liquidation, the Certificate will be suspended and may be withdrawn.
- Reinstatement of a suspended or expired Certificate will be the subject of a review by HiTAC who may consult with Specialist Group 2 if necessary. Certificates which have been suspended or expired for longer than two years will no longer be valid for reinstatement.

3.19 During the validity of any Certificate issued, the BBA will carry out up to two visits each year to each production location and/or the Certificate Holder's offices (where appropriate), to ensure that the procedures and controls defined at the outset continue to apply.

Acceptance of Data Supplied by the Applicant

- 4.1 The BBA will accept test data from external laboratories with UKAS accreditation for the specific tests referred to in Appendix A which are performed on samples approved by the BBA. The BBA would require the test laboratory to submit a copy of their 'UKAS Schedule'.
- 4.2 In the absence of a laboratory meeting the conditions of Section 4.1, the BBA may accept test data from other UKAS accredited laboratories, or BBA Approved Laboratories, that have demonstrated their competence and ability to perform the relevant tests to the satisfaction of the BBA Technical Manager.
- 4.3 Test data from overseas, external, independent testing laboratories that have the equivalent national accreditation for the specific tests may be accepted if there is a reciprocal agreement between UKAS and the national accreditation authority of the country in question, and the test methods used have been demonstrated as being equivalent to the satisfaction of the BBA.
- 4.4 Other data supplied in support of the assessment (eg background information, test data relating to generic materials), where the above conditions are not met, will only be accepted after having been individually assessed and approved as being suitable by the BBA.

Bibliography

- BS 598-110 : 1998 *Sampling and examination of bituminous mixtures for roads and other paved areas, Methods of test for the determination of wheel-tracking rate*
- BS EN 12697-22 : 2007 *Bituminous mixtures — Test methods for hot mix asphalt — Part 22: Wheel tracking*
- BS EN 13036-1 : 2002 *Road and airfield surface characteristics — Test methods — Measurement of pavement surface macrotexture depth using a volumetric patch technique*
- BS EN 13036-4 : 2003 *Road and airfield surface characteristics — Test methods. Method measurement of slip/skid resistance of a surface — The pendulum test*
- BS EN 13108-4 : 2008 *Bituminous mixtures — Material specifications — Part 4: Hot Rolled Asphalt*
- BS EN 13880-2 : 2003 *Hot applied joint sealants — Test method for the determination of cone penetration at 25°C*
- BS EN 13880-3 : 2003 *Hot applied joint sealants — Test method for the determination of penetration and recovery (resilience)*
- BS EN 13880-5 : 2004 *Hot applied joint sealants — Test method for the determination of flow resistance*
- ASTM D 5329 : 2009 *Standard Test Methods for Sealants and Fillers, Hot-Applied, for Joints and Cracks in Asphaltic and Portland Cement Concrete Pavements*
- ISO 9001 : 2008 *Quality management systems — Requirements*
- TRL Report 176 : 1997 *Laboratory tests on high-friction surfaces for highways*
- Manual of Contract Documents for Highway Works, Volume 1 Specification for Highway Works, August 1998 (as amended)*
- Specification for the reinstatement of openings in highways: DfT June 2002*

Appendix A Test Methods and Procedures

Method 1 - Skid Resistance Value (SRV)

The Skid Resistance Value will be determined using the portable skid resistance tester fitted with the narrow slider with CEN rubber and measurements taken on the C scale (126 mm sliding length), generally in accordance with BS EN 13036-4 : 2003 Method for the measurement of slip/skid resistance of a surface – The pendulum test, on a specimen of the System 40 ± 1 mm wide.

The retained SRV will also be determined after the sample has undergone the Wheel tracking test at the required temperature using the appropriate Method 2 or 3.

Note: It will be necessary to calibrate both the narrow slider and wide slider using a 100 mm wide sample.

Method 2 – Retention of Skid Resistance Value (for Overband Systems)

The Overband System is applied 40 ± 1 mm wide, centrally along the long axis, to a 'non-rutting' high stone content unchipped HRA slab (HR 55/14 Surf 40/60 to BS EN 13108-4 : 2008) of minimum thickness 50 mm and dimensions 300 mm by 150 mm. The initial width and thickness of the overband material is measured at the centreline and 50 mm either side using calibrated digital calipers and the initial SRV is measured at room temperature of $23 \pm 2^\circ\text{C}$. The slab is placed in the wheel tracking equipment and tested in accordance with BS 598-110 : 1998(1) at the required temperature depending on the expected durability as detailed in Table 1 of this document.

After testing for 45 minutes the slab is allowed to cool to room temperature and measurements of final SRV, width and thickness are taken.

Three samples of each product are tested and the mean values determined.

- (1) It is proposed that in the future the wheel tracking test is replaced by the method defined in BS EN 12697-22 : 2003 (small device. Procedure-B). Comparative testing will therefore be carried out until such time as a correlation can be established between the two procedures. Until then, the procedure defined in BS 598-110 : 1998 will be used to confirm compliance with the relevant requirements given in Tables 3 or 4 of this document.

Method 3 – Retention of Skid Resistance Value (for Fill and Overband Systems)

The system is applied centrally along the long axis to a concrete slab of minimum thickness 50 mm and dimensions 300 mm by 150 mm with a 'V' channel 30 mm wide by 23 mm deep running centrally along the long axis of the slab (see Figure 2). The 'V' channel is formed (using a former) at the time of manufacture of the slab.

Figure 2 Fill and Overband test specimen

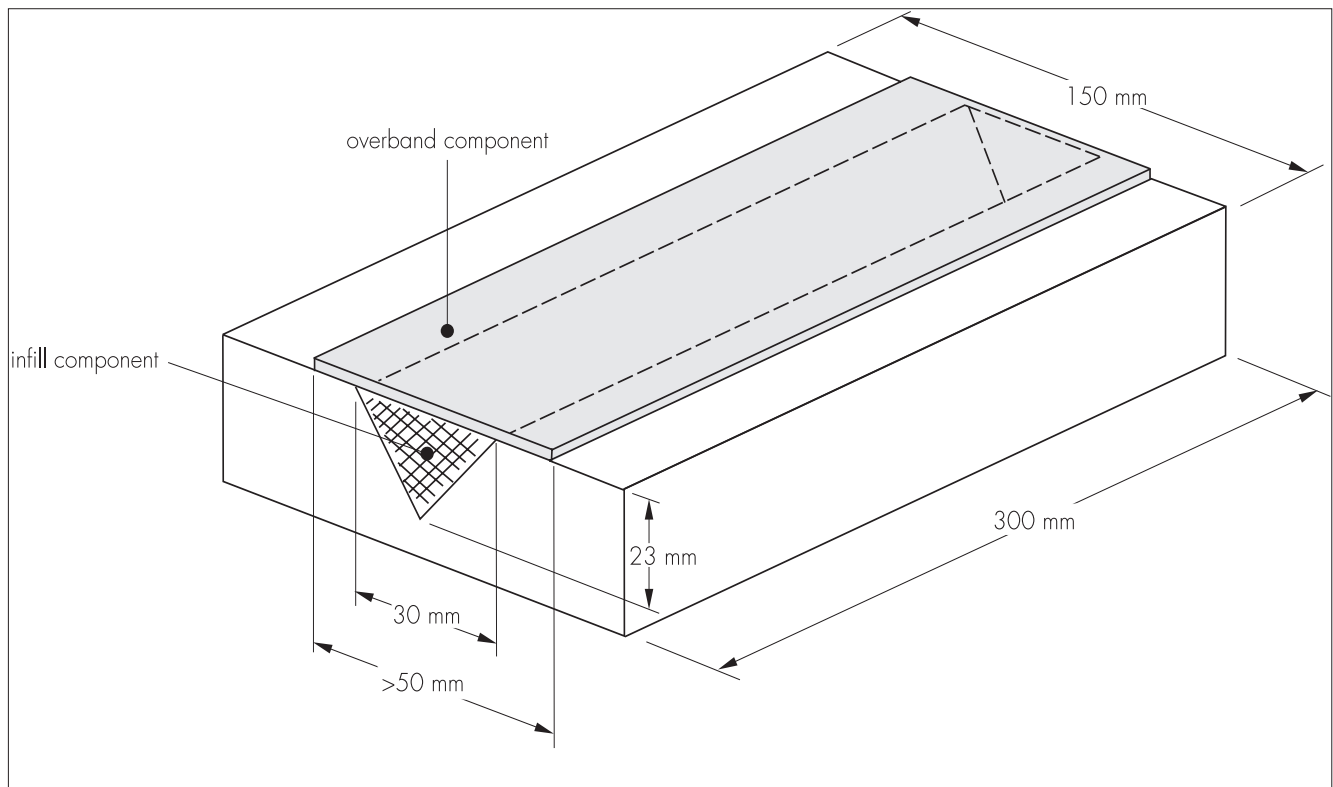

The 'V' channel is filled with the 'Fill' component of the system in accordance with the manufacturer's instructions. The overband component is then applied over the fill component and to overlap onto the HRA slab surface in accordance with the manufacturer's instructions.

The initial width and thickness of the overband material is determined along the centreline at five equally spaced points using calibrated digital calipers and the initial SRV and texture depth (if required) are measured at room temperature of $23 \pm 2^\circ\text{C}$.

The slab is placed in the wheel tracking equipment and tested in accordance with BS 598-110 : 1998⁽¹⁾ at the required temperature depending on the expected durability as detailed in Table 1 of this Guideline.

After testing for 45 minutes the slab is allowed to cool to room temperature and the width and thickness after wheel tracking measured at the same points as the initial measurements taken above. The SRV and texture depth (if required) after wheel tracking are also determined at room temperature of $23 \pm 2^\circ\text{C}$. Three samples of each product will be tested and the mean values determined.

(1) It is proposed that in the future the wheel tracking test is replaced by the method defined in BS EN 12697-22 : 2003 (small device. Procedure-B). Comparative testing will therefore be carried out until such time as a correlation can be established between the two procedures. Until then the procedure defined in BS 598-110 : 1998 will be used to confirm compliance with the relevant requirements given in Tables 3 or 4 of this document.

Method 4 — Rut Resistance and Retention of Skid Resistance Value (for Inlaid Sealing Systems)

For Inlaid Sealant Systems three test specimens are made up on a 50 mm thick 'non-rutting' high stone content unchipped HRA slab (HR 55/14 Surf 40/60 to BS EN 13108-4 : 2008) consisting of the Inlaid system applied at a minimum thickness of 20 mm or at the manufacturer's maximum declared thickness if greater than 20 mm.

Measurements for initial texture depth and initial SRV are taken at room temperature of $20 \pm 2^\circ\text{C}$ before the specimen is placed and tested for 45 minutes in the wheel tracking equipment at $50 \pm 2^\circ\text{C}$ and the rut rate and rut depth determined in accordance with BS 598-110 : 1998⁽¹⁾⁽²⁾.

Following wheel tracking the SRV and texture depth are again measured at $20 \pm 2^\circ\text{C}$ and the retained SRV and texture depth calculated.

Three samples will be tested, and the mean values determined.

- (1) The rut resistance test may result in a 'shoulder' of material occurring at the edges of the tracked area. To enable the SRV to be measured it may be necessary to cut off the edges outside the tracked area.
- (2) It is proposed that in the future the wheel tracking test is replaced by the method defined in BS EN 12697-22: 2003 (small device. Procedure-B). Comparative testing will therefore be carried out until such time as a correlation can be established between the two procedures. Until then the procedure defined in BS 598-110 : 1996 will be used to confirm compliance with the relevant requirements given in Tables 3 or 4 of this document.

Method 5 — Texture depth

When required, texture depth is measured in accordance with the amended Draft Linear Sand Patch Test method on the samples prior to and after the Rut Resistance test (Method 3), as follows:

- A natural sand with a rounded particle shape will be used.
- The grading of the sand is within the sieve range passing through the 150 μm and retained in the 75 μm sieves.
- The finely graded sand is poured from a container into a cylinder having a volume of 5.0 ± 0.1 ml.
- The sand is spread in such a way that an oblong shape is produced having parallel edges (as far as is practicable) using a 40 mm wide screed box filled with 5 ml(1) of sand by drawing the box along the surface until all the sand has been used.
- The texture depth (TD) is calculated as:
 - $TD = V \times 103 / L \times W$ Equation 1
 - where TD = texture depth (mm)
 - V = volume of sand (ml)
 - L = length of patch (mm)
 - W = width of patch (mm)

(1) For texture depths >2 mm the volume of sand should be increased to (10 ± 0.1) ml.

Note for guidance: For a 40 mm wide sand patch the maximum spread lengths required to achieve the minimum TD before and after the Rut Resistance test are: L < 83 mm (initial) L < 166 mm (after wheel tracking)

Method 6 – Flow rate of filled material

The flow characteristics of hot poured bituminous Fill and Overbanding materials for the sealing of cracks between 5 mm and 20 mm wide are measured using a modified Zahn Cup with an aperture of 9.5 ± 0.1 mm in accordance with the following method:

- A sample of material (1000g - 2000g) is heated progressively in a suitable melting pot until the Applicant's minimum recommended installation temperature is reached and maintained. Using the Zahn Cup measure and record the efflux time at this temperature and at increasing temperature increments of 5°C until the Applicant's maximum recommended installation temperature is attained. Care should be taken to ensure that the Zahn Cup is held still whilst taking the efflux time readings.
- After taking the above set of readings determine the temperature at which the efflux time is equal to 20 seconds. This temperature is the minimum recommended temperature for the filling of crack widths of 5 mm to 20 mm.

Method 7 – Elongation

The material under test is melted and poured between two concrete mortar blocks to produce a test piece of dimensions 25 mm thick by 50 mm wide by 50 mm deep. (See ASTM D5329: 2009). The test specimen is placed in a tensile test machine and extended at a crosshead rate of 6 mm per hour at $23 \pm 2^{\circ}\text{C}$.

During the test the extension of the sample and the load developed are recorded. On completion of the test the maximum load and appearance of the sample are recorded. The test is taken to 30% extension.

Three test samples are required and the system will be deemed to have met the requirements provided the body of each specimen is largely intact (ie no major splits).

Method 8 – Yield Strain

The material under test is heated up to the manufacturer's declared application temperature and poured into a silicone mould with dimensions 100 mm long by 90 mm wide by 40 mm deep. This is then allowed to condition at room temperature for 24 hours before being released from the mould. Three test specimens are required.

The sample measurements, specimen bonding, testing and calculations are conducted in accordance with TRL Bituminous Yield Strain Test Paper dated 1 February 1995 to give the percentage yield strain. Each test sample should achieve a minimum yield strain value of 2.5%

Appendix B Definitions and Acronyms

| | |
|---------------------------|---|
| BBA | British Board of Agrément |
| BBA Approved Laboratory | A laboratory approved by the BBA to carry out test work on behalf of the BBA, ie subcontracted by the BBA, which may lead to the approval of a product and the issue of a BBA Certificate. Before approval, the laboratory will have demonstrated to the BBA that it has the relevant expertise, equipment and quality systems in place to carry out the work required. |
| Certificate of Conformity | A Certificate providing evidence that a material has been tested and meets any required performance / specification requirements. A Certificate of Conformity will be traceable to a specific batch or delivery of the material and will normally be required to show the results of agreed performance / specification tests. |
| COSHH | Control of Substances Hazardous to Health. |
| CSS | County Surveyors Society |
| HA | Highways Agency, also representing other Overseeing Organisations including The Scottish Office Industry Department, The Welsh Office and The Department of the Environment for Northern Ireland. |
| HAPAS | Highway Authorities Products Approval Scheme |
| HiTAC | Highways Technical Advisory Committee. A committee, appointed by the Council of the BBA, consisting of representatives of parties responsible for overseeing and controlling the HAPAS scheme and the work of the BBA in this area. |
| Specialist Group | A Specialist Group formed under the auspices of HiTAC. The objectives of the Group are to develop guidelines and offer specialist advice for the assessment and Certification of products for highways. |
| TRL | Transport Research Laboratory |
| UKAS | United Kingdom Accreditation Service |
| Visual Observation | A visual procedure for assessing the condition of sites, including photographic evidence, is carried out on the installation, during daylight hours for uniform surface texture and any discernible faults. |